



HRL-0100-1 HEATLESS  
DESICCANT AIR DRYER  
GENERAL ARRANGEMENT

TOLERANCES UNLESS  
OTHERWISE SPECIFIED:

FRACTIONS = ± 1/4 "  
ANGLES = ± 3°  
INCHES = ± 1/2 "  
FINISH = 250

THE SPECIFICATIONS AND DRAWINGS DISCLOSED HEREIN ARE THE SOLE PROPERTY OF ALTEC AIR, AND SHALL NOT BE  
COPIED OR USED AS THE BASIS FOR SALE OR MANUFACTURE WITHOUT EXPRESS WRITTEN PERMISSION.

REVISION LOG

REV.	ECO.	DESCRIPTION	DATE	APPROVED
H	1304	PRODUCTION UPDATES	8/29/2022	WS

DRAWING NO.

AT20-522

REV.  
H

DRAWN: MR

DATE: 2/24/2015

CHECKED:

DATE:

SCALE: N/A

SHEET: 1 OF 2

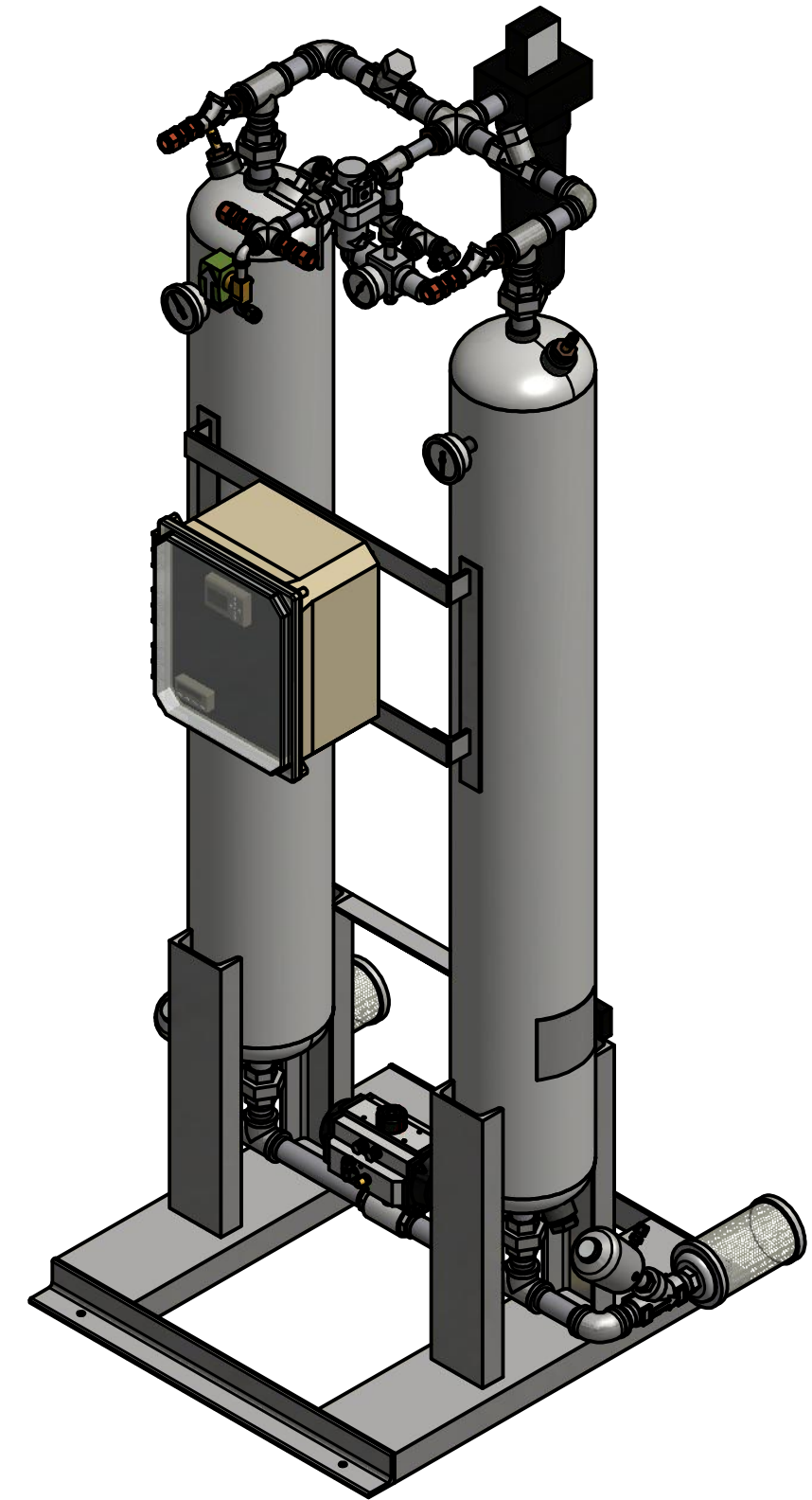
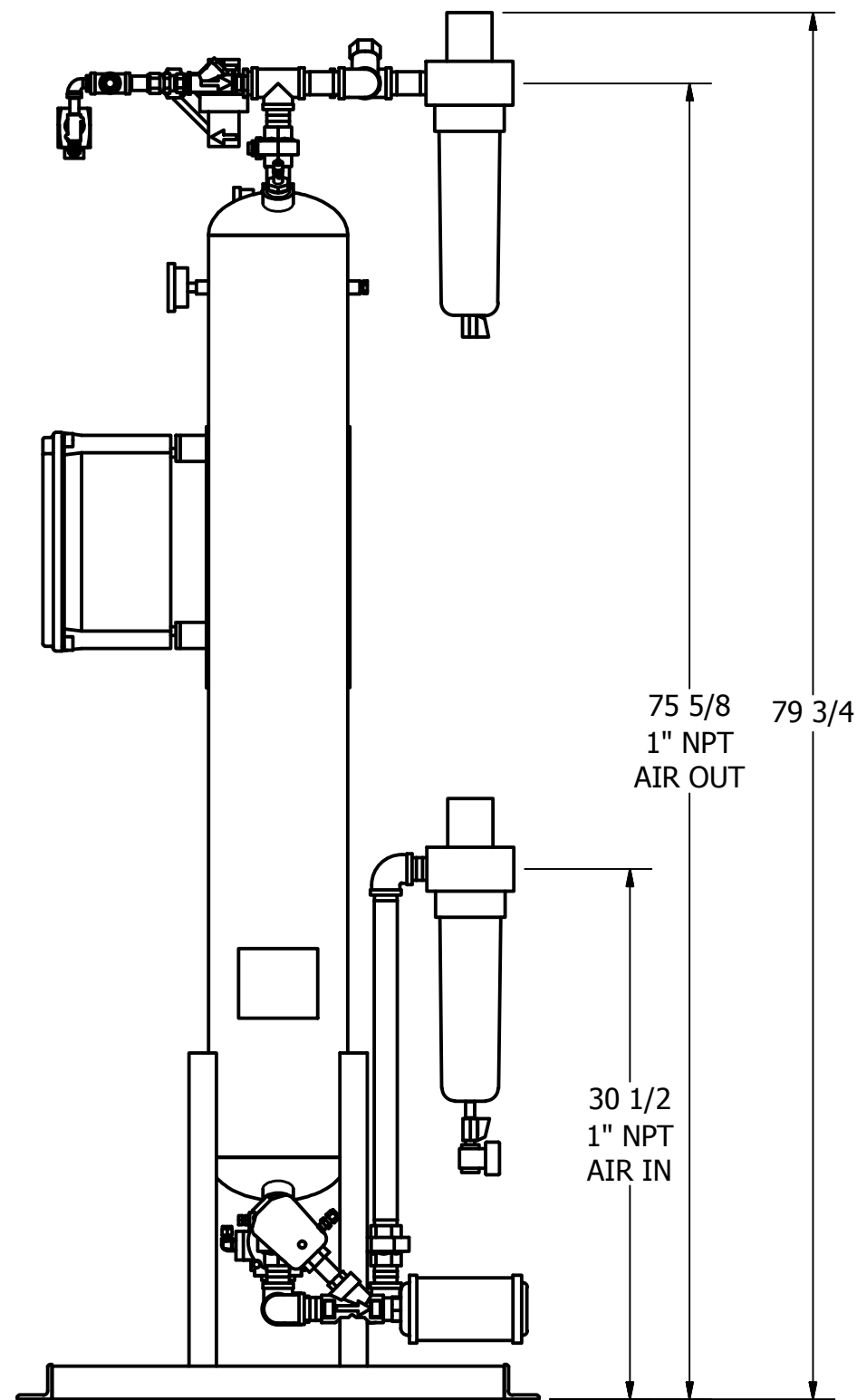
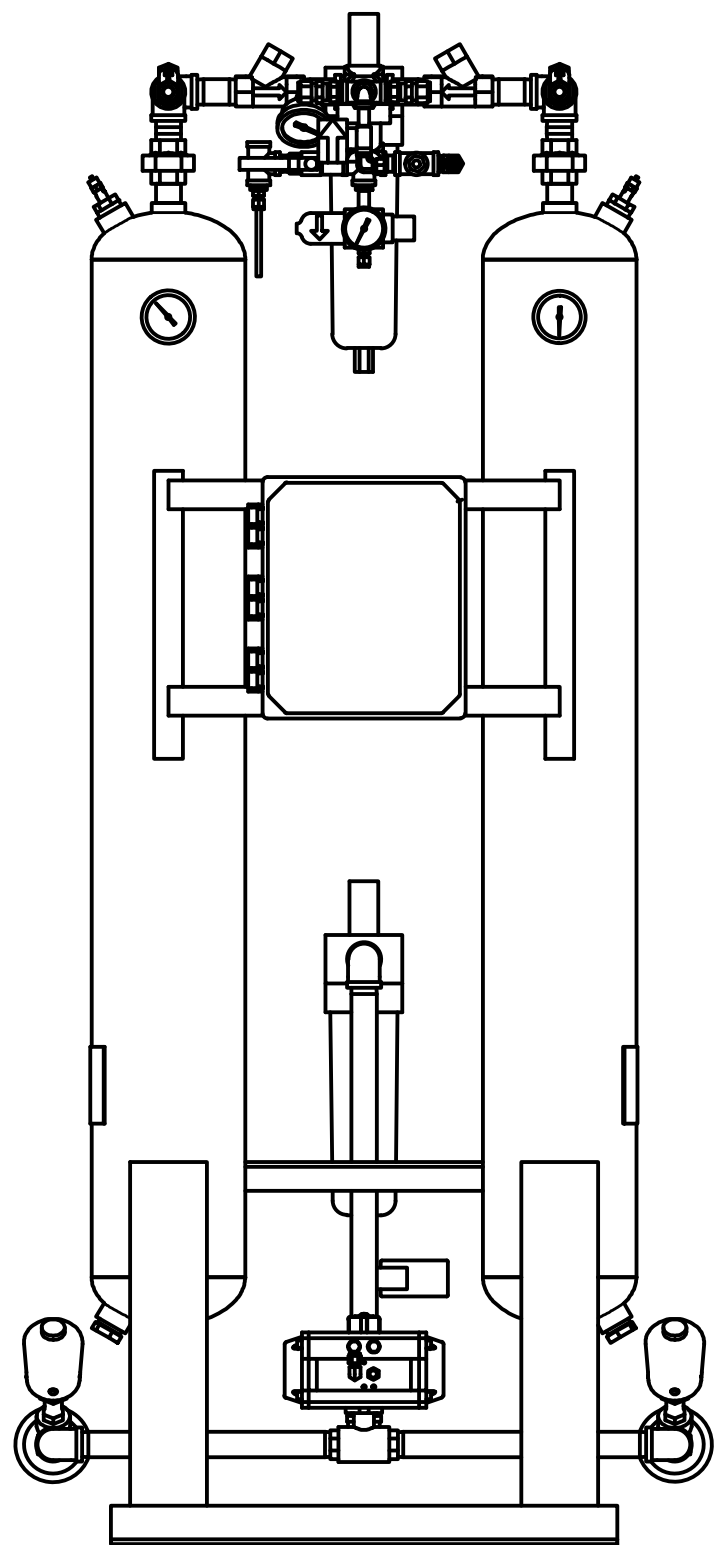
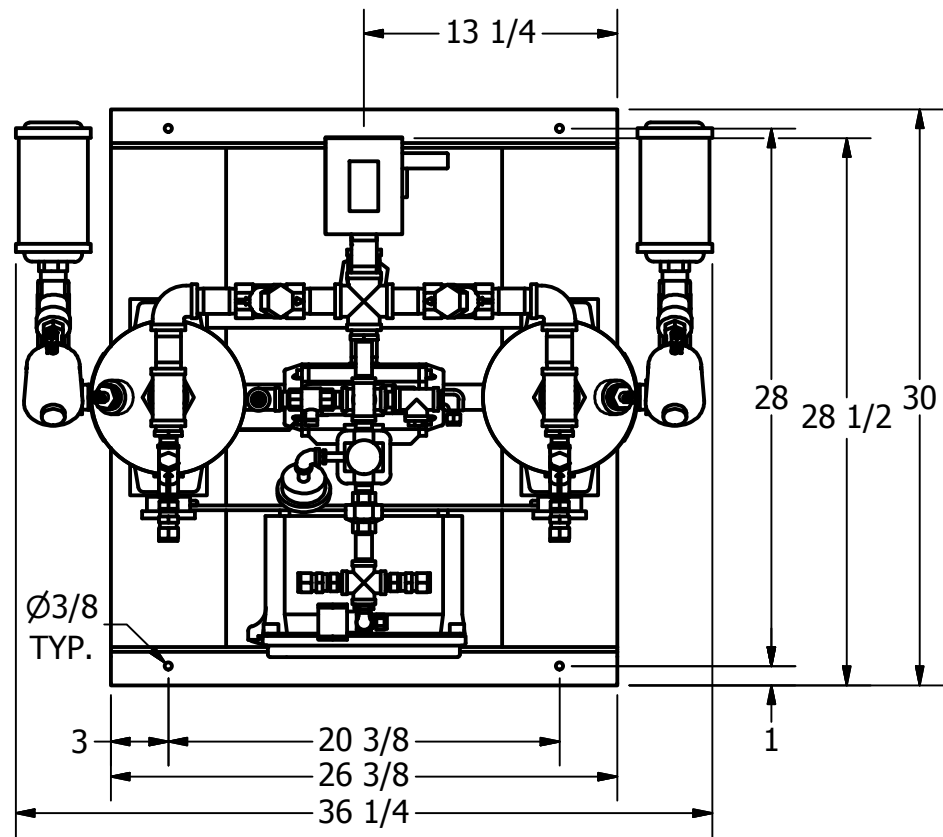

**PRELIMINARY**



# HRL-0100-1 HEATLESS DESICCANT AIR DRYER GENERAL ARRANGEMENT

TOLERANCES UNLESS  
OTHERWISE SPECIFIED:

- FRACTIONS = ± 1/4 "
- ANGLES = ± 3°
- INCHES = ± 1/2 "
- FINISH = 250

THE SPECIFICATIONS AND DRAWINGS DISCLOSED HEREIN ARE THE SOLE PROPERTY OF ALTEC AIR, AND SHALL NOT BE COPIED OR USED AS THE BASIS FOR SALE OR MANUFACTURE WITHOUT EXPRESS WRITTEN PERMISSION.

### REVISION LOG

REV.	ECO.	DESCRIPTION	DATE	APPROVED
H	1304	PRODUCTION UPDATES	8/29/2022	WS

DRAWING NO.

**AT20-522**

REV.  
**H**

DRAWN: MR      DATE: 2/24/2015  
CHECKED:      DATE:

SCALE: N/A      SHEET: 2 OF 2

### PARTS LIST

ITEM	QTY	DESCRIPTION
1	2	CHECK VALVE, PURGE
2	1	PRESSURE REGULATOR, PURGE
3	1	PRESSURE GAUGE, PURGE
4	2	CHECK VALVE, OUTLET
5	1	PARTICULATE AFTER-FILTER
6	1	DEW POINT MONITOR (OPTIONAL)
7	1	SOLENOID VALVE, REPRESS
8	1	MOISTURE INDICATOR
9	2	RELIEF VALVE, TANK
10	1	PRESSURE REGULATOR, CONTROL
11	1	PRESSURE GAUGE, CONTROL
12	2	PRESSURE GAUGE, TANK
13	1	3-WAY BALL VALVE, INLET
14	1	COALESCER PRE-FILTER
15	2	ANGLE BODY VALVE, EXHAUST
16	2	MUFFLER, EXHAUST
17	110 LBS	DESICCANT

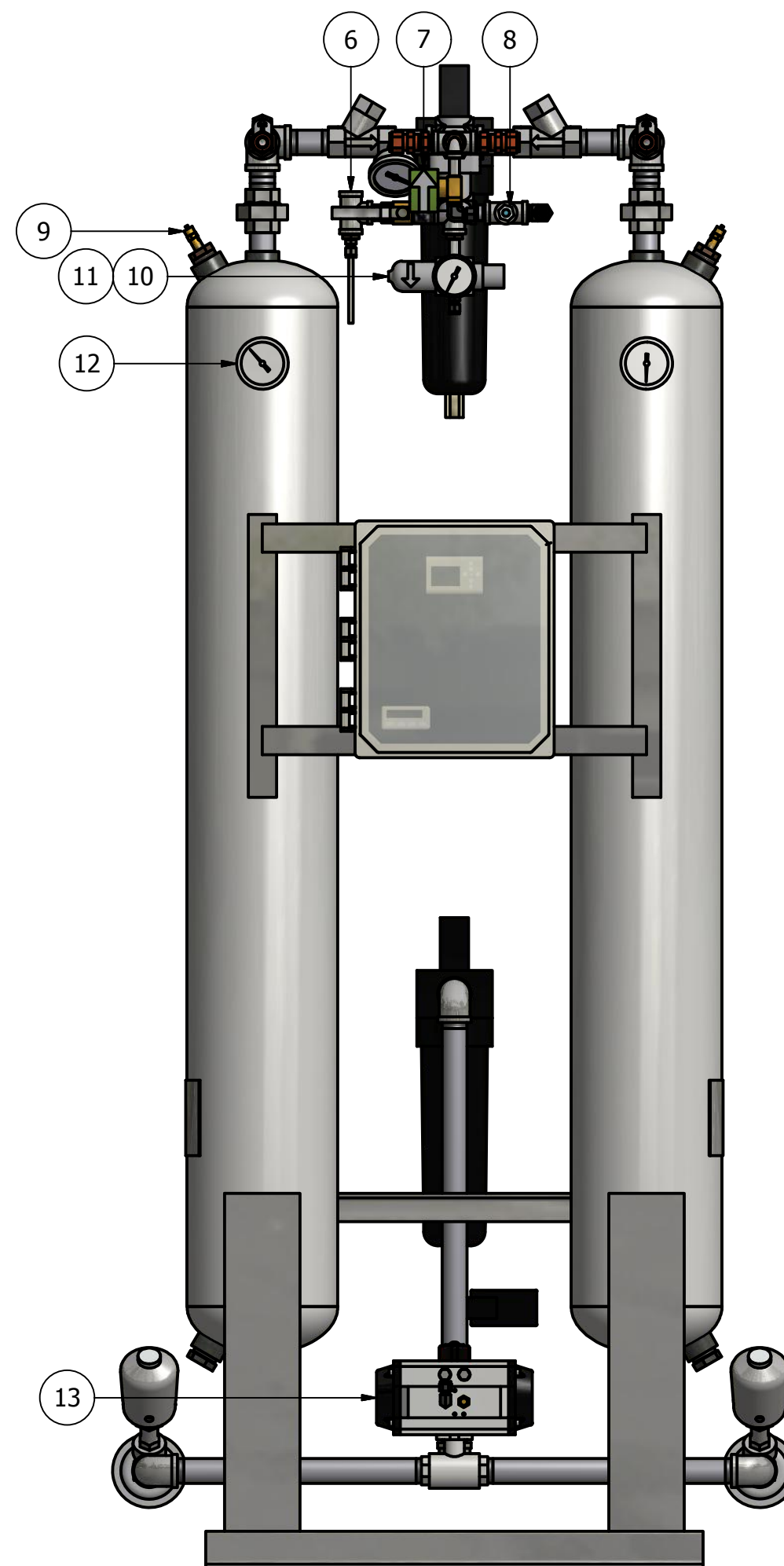
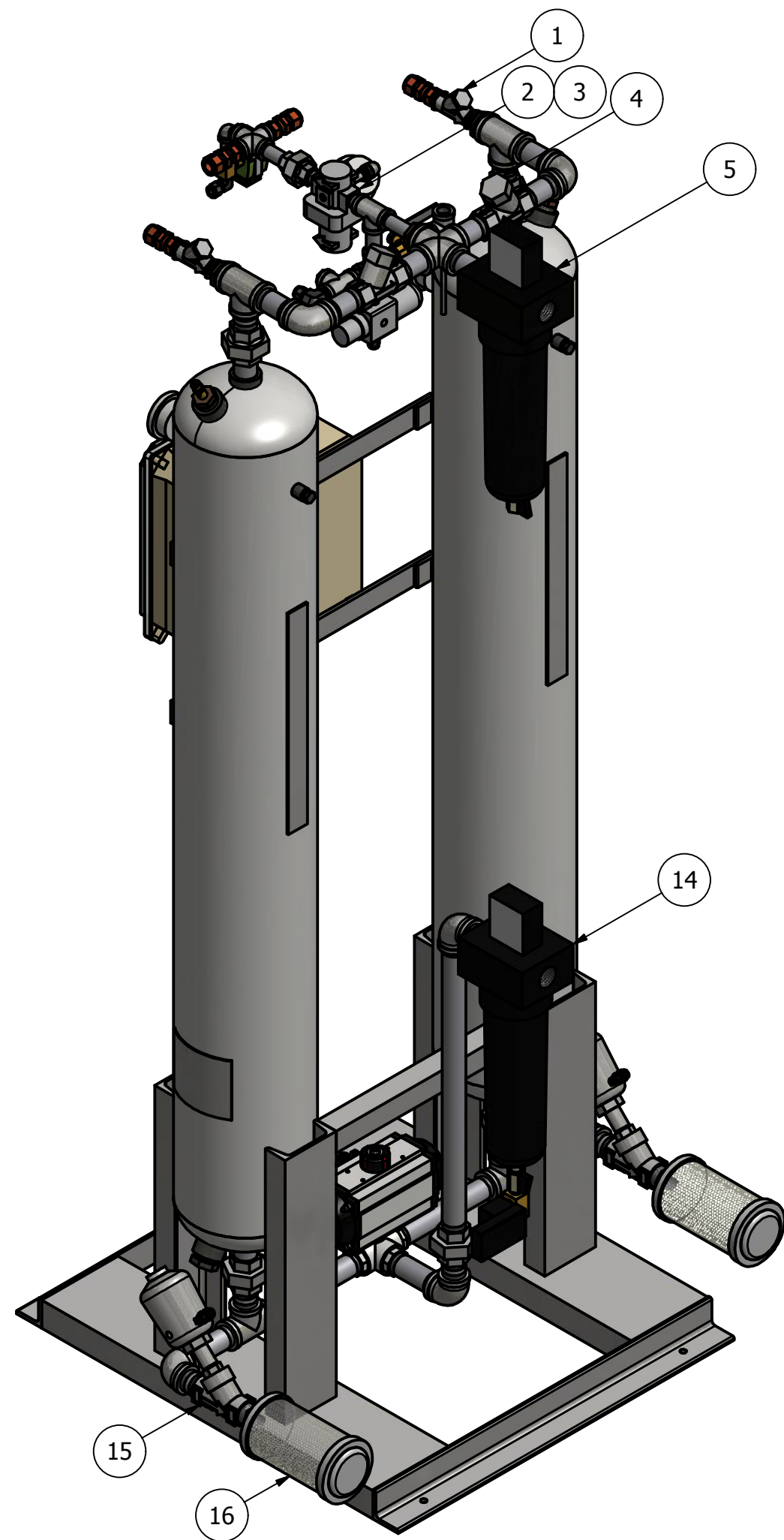

**PRELIMINARY**